

The impact of sound  
on computer hard  
disk drives and risk  
mitigation measures



## // Table of Contents

Introduction to Data Center Acoustic Sensitivity	1
Analysis of Hard Disk Drive Acoustic Performance	1
The Metrics of Measuring and Defining Sound	4
The Source-Path-Receiver Paradigm	4
Sound Measurement scales	5
Noise frequency bands	6
Data Center Sound Pressure Level Calculations	6
Fire Suppression Nozzle Sound Characterization	7
Tyco Acoustic Nozzle Solution and Performance	7
Tool to Estimate System Sound Performance in a Specific Hazard Area	9
Additional Recommend Noise-Control Measures	10
About the Authors	10
References	11

## Introduction to Data Center Acoustic Sensitivity

Data centers are relied upon to store and distribute valuable information from customers across many industries, from the investment banking to the healthcare sector. This valuable information is primarily stored on Hard Disk Drives (HDD). Industry demands that data centers remain functional 24 hours a day, 7 days a week, 365 days a year. Downtime can damage the reputation of a data center and result in the loss of customers. The data center market aims to continuously reduce the risk of downtime or lost operation time.

One method to help reduce that risk is to install inert gas fire suppression systems. Data center fire suppression system discharges (Rawson & Green, 2007) along with independent testing (Nickerson, Green, & Pai, 2013) have shown that HDD performance may be reduced or permanent HDD damage may occur due to exposure to high acoustic levels. In order to gain a greater understanding of the impact of acoustic energy on hard drives, Tyco Fire Protection Products (Tyco), in conjunction with Michigan Technological University (MTU) conducted a holistic study of HDD performance with respect to acoustic energy, room acoustics, and suppression system nozzle acoustics. This paper incorporates the results of that study and covers the following topics:

## Analysis of Hard Disk Drive Acoustic Performance:

Characterization of noise induced performance degradation of a sample set of HDDs typically installed in data centers.

## Understanding Sound Measurements:

Introduction to the acoustic source-path-receiver model and proper sound measurement metrics.

## Suppression System Discharge Acoustics:

An overview of the sound generated during fire suppression discharge events. Analysis of nozzle technology specifically designed to lower the sound pressure within the protected area which reduces the acoustic-induced damage to hard disk drives.

## Acoustic Calculator:

A method to estimate the sound pressure level within a protected data center.

## Additional Risk Mitigation

**Actions:** Identification of additional actions that can help to reduce sound pressure levels in data centers.

## Analysis of Hard Disk Drive Acoustic Performance

Hard Disk Drives are storing the information of the connected world. HDD technology continues to evolve in terms of storage capacity and access speeds. Over the past few years, evidence has been building that suggest HDDs have become more sensitive to noise as the technology evolves. In order to quantify the acoustic sensitivity of current HDDs, Tyco initiated a joint research project with the Dynamic Systems Laboratory at Michigan Technological University. Together, Tyco and MTU developed a robust scientific approach to analyze and quantitatively document the acoustic sensitivity of HDDs.

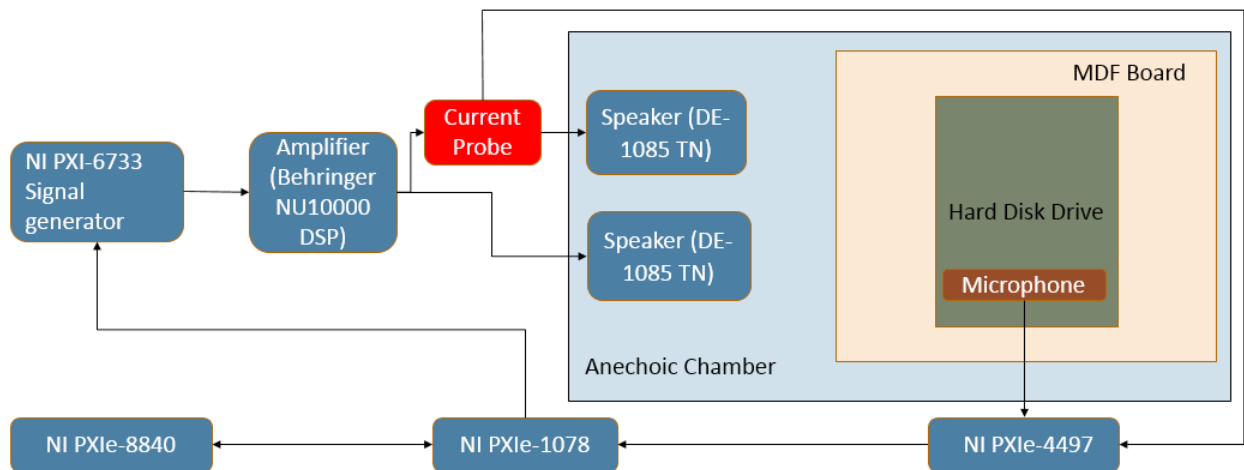
A sample of 12 enterprise model HDDs were selected to represent the population of HDDs that are commonly found in today's data centers. The 12 HDDs contained samples from five different brands, with capacities ranging from 320 gigabytes to 10 terabytes.

The MTU Dynamic Systems Laboratory established an experimental test set-up designed to quantify the read/write performance reduction of HDDs when exposed to noise across frequency bands and at varying sound pressure levels. The test setup employed a data acquisition system to control the testing process, record the sound pressure levels (SPL) in one-third octave (OTO) bands and evaluate the HDD read/write speeds.

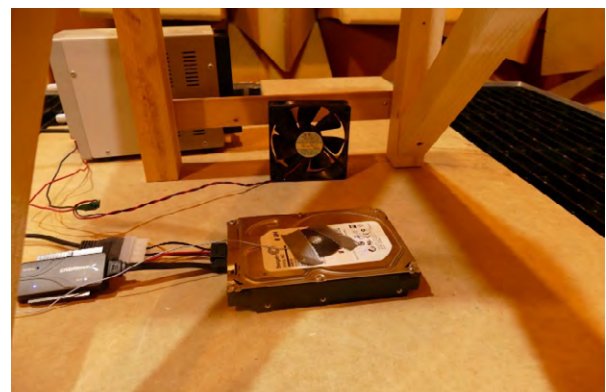
The HDDs were placed in an anechoic chamber (sound proof chamber) to avoid unwanted path effects, such as reflections, or spurious external noise sources. The testing setup ensured precise control of the noise SPL at the surface of the HDD by utilizing a real time control system capable of dynamically adjusting the input signal to the noise source.

This SPL control was achieved by means of a feedback loop in the data acquisition system. The feedback control system consisted of a power amplifier, compression drivers, an electrical current probe and a surface-mount microphone located on the top surface of the HDD. The data acquisition system used the real-time SPL reading at the HDD to adjust the

noise output of the compression drivers and ensure a constant noise application during each test. The unweighted SPLs were measured in one-third octave (OTO) bands. The block diagram of the test measurement and feedback control system is shown in Figure 1. Figure 2 shows photographs of the experimental test set-up.



**Figure 1:** Block diagram of the test set-up. The HDDs were placed in an anechoic chamber and were exposed to sound produced through the speakers by the signal generator.

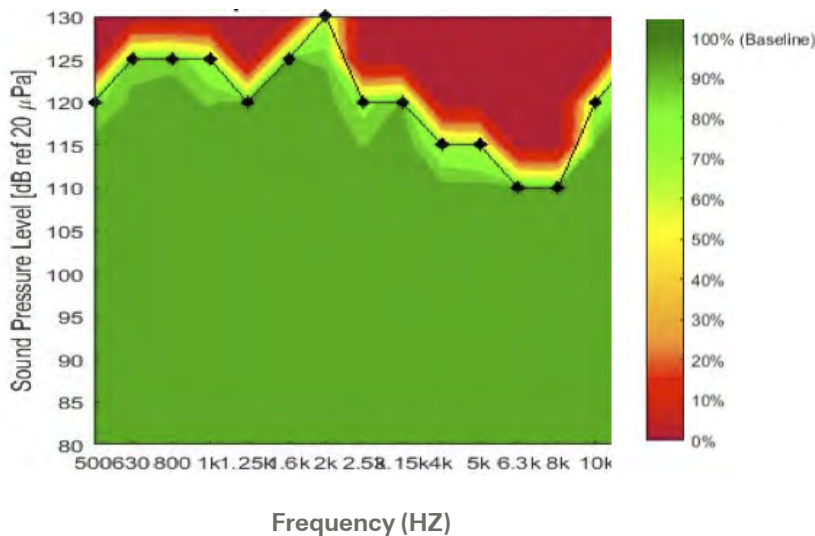


**Figure 2:** Photograph of the test set-up showing the HDD on an MDF board in the anechoic chamber at Michigan Technological University with the speakers placed 0.5 m above the HDD (left). The surface mount microphone, a fan used for cooling the HDD and the USB 3.0 cables used for performance test (right).

The HDD performance during the acoustic testing was captured by monitoring the drive read/write speeds. The read/write performance was conducted using a random process of different sized data packets. The block sizes of the data packets varied from 10 KB to 8 MB. The write test was performed first followed by the read test for all experiments. Baseline read/write speed tests, with no sound source present, was captured for each HDD to establish the normalized 100% drive performance level. Once the baseline was established, the HDDs were then subjected

to the acoustic sensitivity testing. Several baseline tests were conducted throughout the evaluation of each HDD to ensure no permanent damage had been induced by the testing. Each of the HDDs were exposed to noise in OTO bands from 500 Hz to 10 kHz for sound pressure levels at the HDD surface ranging from 80 dB to 130 dB (re 20  $\mu$ Pa). The noise was increased in 5 dB increments until the drive read/write speed performance was reduced by 50% from the baseline. The threshold of acceptable performance was defined as a 50% reduction in the baseline HDD read/write performance.

This limit was established because HDD performance was noticed to rapidly decline at sound pressure levels above the 50% performance reduction point. Figure 3 shows an example of the rapid reduction in performance at SPLs above the 50% performance curve. During individual HDD testing, when the 50% reduction in performance was identified at each OTO band, the experiment was stopped for that OTO band and testing was continued at the next OTO band. The list of HDDs tested are shown in Table 1.



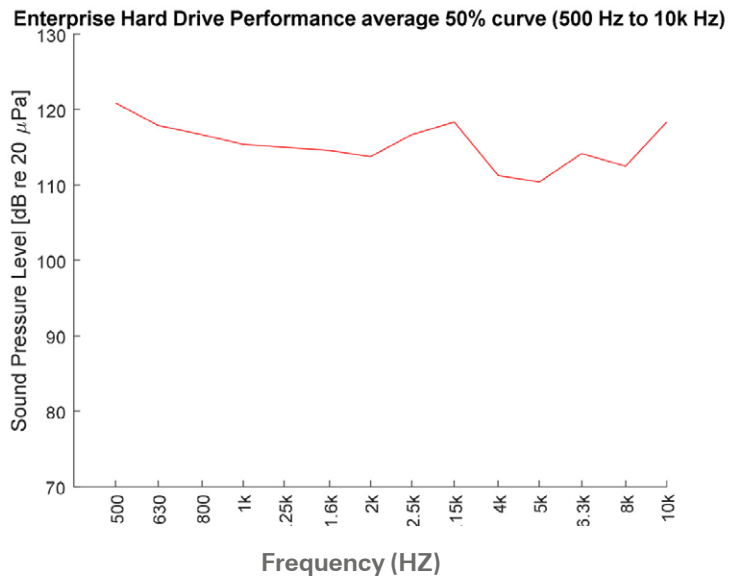
**Figure 3:** The minimum read and write speeds as percentage of their respective baseline values shown in OTO frequency bands. The performance of the HDD drops dramatically after reaching the 50% curve shown by the black curve with black diamond data points.

Brand	Memory Size	Helium filled?
A	8 TB	YES
B	320 GB	NO
B	2 TB	NO
B	1 TB	NO
C	500 GB	NO
C	500 GB	NO
D	6 TB	NO
D	6 TB	NO
D	10 TB	YES
E	6 TB	NO
E	6 TB	NO
E	10 TB	YES

**Table1:** Table of 12 HDDs tested

Figure 4 shows the average 50% curve for the 12 different HDDs tested across the 500 Hz to 10 kHz frequency range. The average 50% performance reduction curve indicates that an SPL of approximately 110 dB (re 20  $\mu$ Pa) in any OTO band is likely to cause reduced performance in HDDs.

**However, SPL values for some drives within the test samples experienced reduced read / write speeds while exposed to sound as low as 85 dB (re 20  $\mu$ Pa).**



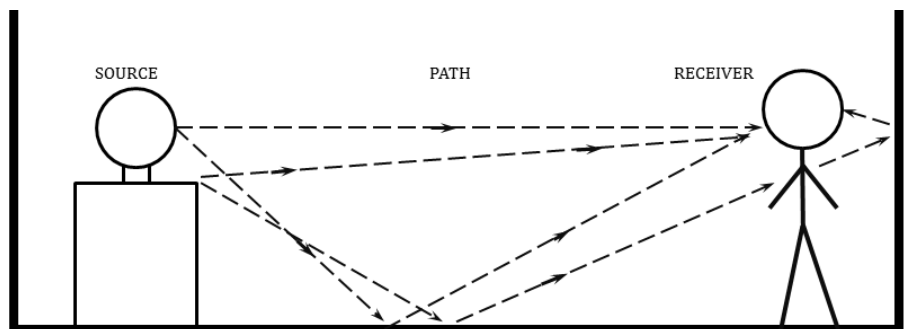
**Figure 4:** The SPL at one third octave frequency bands where the performance of the HDD was reduced by 50 % from the baseline values. The plot in the red shows the average of the 50 % points for 12 different HDDs.

## The Metrics of Measuring and Defining Sound

### The Source-Path-Receiver Paradigm

There are several different measurements that can be made and metrics that can be used to quantify sound amplitude and frequency. When investigating noise control problems, consider the source-path-receiver paradigm represented in Figure 5. a number of filters in order to easily select the specific points within the system.

The source-path-receiver paradigm provides insight into the measurements necessary to define and address



**Figure 5:** Source- Path- Receiver Paradigm

acoustic issues in data centers. The **source** is a system, sub-system, or component that is generating noise, the **path** is any combination of

acoustic or structural paths the energy can take to travel from the source to the receiver and the **receiver** is the person,

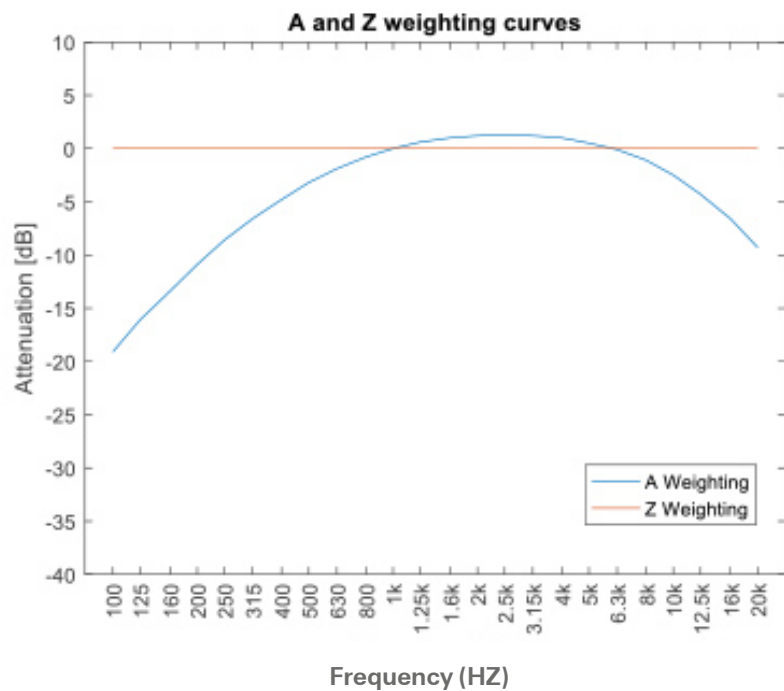
instrument, or object that can be affected by the noise. Although this definition may seem simplistic, it is a powerful concept to help understand the parameters impacting acoustic measurements.

Agent discharge nozzles and detection alarms that are part of inert gas fire suppression systems are sources of sound. If these sources are moved around a room or from room-to-room, they will not sound the same (i.e. their measured sound pressure levels at a specified distance from the source will not be constant), due to changing path characteristics. The SPL measurements cannot be immediately compared from one room to another unless the path characteristics are known. Therefore, to correctly quantify the sound output of a source, a sound metric independent of the distance between the source and receiver and independent of the path must be used. This measurement metric is **sound power level** (dB re 1 picowatt) (Barnard, 2014). Sound power level measures the total acoustic energy per unit time emitted from a source. Unlike sound pressure level, sound power level is only a function of the source and is independent of measurement distance and other path effects.

## Sound Measurement scales

As a source emits acoustic power, that energy is transmitted through the path to the receiver, which may be the human ear or other mechanical devices, depending on the problem being addressed. Many SPL measurements default to the A-weighting scale, designated by "dBA". A-weighting is frequency-dependent and reflects the non-linear response of the human ear at modest

sound pressure levels (See Figure 6). However, a hard disk drive (HDD) exposed to sound pressure levels does not react to sound pressure in the same way as a human ear. Therefore, the sound pressure level received by a HDD should not be measured in units of dBA, but instead an unweighted sound measurement, Z-weighting (dBZ), should be used.



**Figure 6:** One-third octave band frequency domain depiction of A and Z weighting.

## Noise frequency bands

It is important to understand that noise will affect each model or manufacturer of HDDs in unique ways. The varying design of HDDs will result in certain frequencies causing HDD sensitivity due to component vibrations (structural modes). The structural modes of each HDD are a key factor in noise-induced failure. Because of this, it is important to understand the frequency-dependent characteristics of both the noise source and the response of the receiver. In room acoustics, scientists use logarithmically distributed, band limited frequency ranges known as one-third octave (OTO) bands. In addition to the frequency content, the noise should also include measurement of magnitude (in terms of dBZ). For suppression nozzles, the sound power is required to define the magnitude of the noise generated. Nozzle sound power measurement allows for the direct comparison of one nozzle design to another, regardless of the testing environment. If suppression nozzles are not characterized by sound power but rather stated in terms of sound pressure level (SPL) at a distance from the nozzle, the characterization can be misleading. For example, there could be significant undisclosed path absorption factors in the test setup that reduced the reported sound pressure readings captured by a microphone. There could also

be constructive or destructive interference in a reflective measurement environment. This will mean that the reported performance will only be valid for a server room set up that is identical to the test set up. This will almost never be the case.

## Data Center Sound Pressure Level Calculations

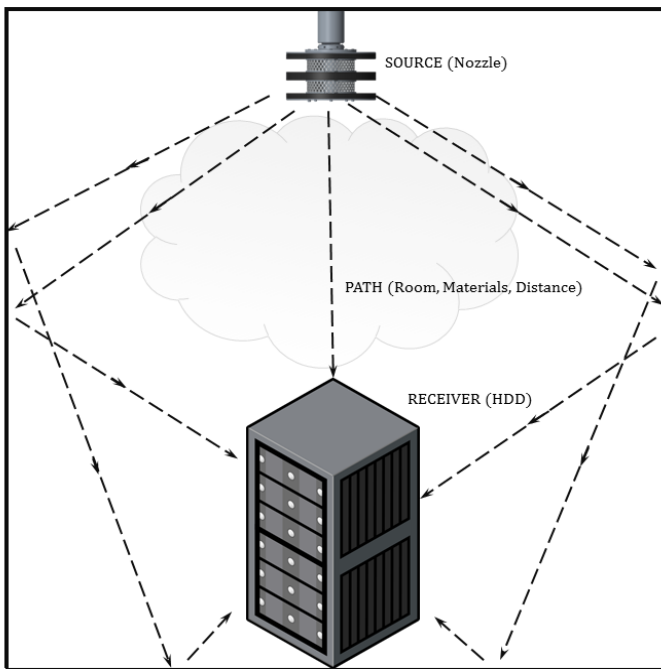
Measuring the sound power level of the nozzle also allows for the use of acoustic engineering principles that can more accurately predict the sound pressure level of a receiver, which in the case of data centers would be the HDD. Established acoustic engineering equations require additional data to define the path characteristics of the room in order to predict a sound pressure level. This data includes the distance between the source and the receiver and the total acoustic absorption within the sound path. The results determined by using the acoustic equations can help a designer to select the appropriate nozzle and its placement, HDD placement within a room, and the room construction materials to achieve the desired sound pressure level at the HDDs. Data center owners and operators must consider the source-path-receiver paradigm and understand that sound is generated as sound power at a source and transformed through the room paths to generate the sound pressure at HDDs. Figure 7 shows the model and measurements for a typical data center using the source-path-

receiver paradigm for the inert gas fire suppression.

Measurements required for the fire suppression system-path-receiver model are as follows:

- The suppression nozzle sound output should be measured in frequency-dependent source sound power level (dB re 1 pW) at OTO bands from 500 to 10K Hz. To obtain an accurate sound power measurement, the testing should be performed using a data acquisition system with randomly placed multiple microphones (8 or more) within a calibrated reverberation enclosure (**Acoustical Society of America, 2012**).
- Hard drive noise performance curves are frequency-dependent and must be measured in unweighted SPL (dBZ re 20  $\mu$ Pa) at OTO bands from 500 to 10K Hz.
- To estimate the room's path characteristics, the material's acoustic properties and surface area within the room must be known or determined through testing.
- The predicted SPL of a HDD is also dependent on the distance to the nearest suppression nozzle.

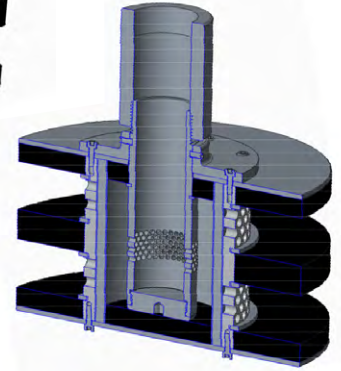




**Figure 7:** Example of Source-Path-Receiver Paradigm for a fire suppression system in data centers



**Figure 8:** Acoustic Nozzle Exterior View



**Figure 9:** Acoustic Nozzle Section View

## Fire Suppression Nozzle Sound Characterization

The sound output of fire suppression systems is dependent on many factors. The factors that have influence include discharge duration, peak agent flow rate, valve technology and many others. The standard discharge control method in inert gas suppression technology for many years has been metering orifices. These systems have proven reliability and a track record of suppressing fire events. One characteristic of this orifice flow technology is high peak agent flow rates through nozzle orifices that generate high noise levels. Testing has determined that the nozzle sound power of orifice flow system discharges can exceed 145 dB. Tyco’s recently introduced iFLOW regulated flow technology that has been shown

to have a reduced sound power level per nozzle of approximately 138 dB. Reviewing the performance characterization of HDDs, generated through the testing with MTU, it became evident that a solution was needed to lower the sound power of suppression nozzles even further to prevent HDD degradation.

## Tyco Acoustic Nozzle Solution and Performance

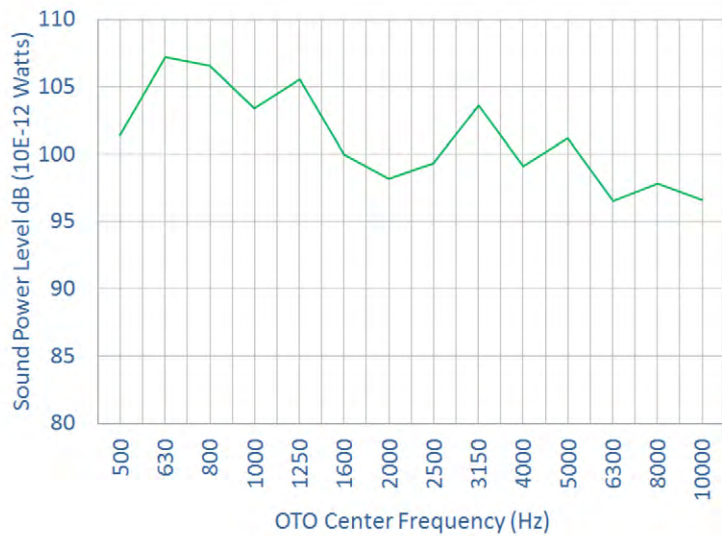
Tyco performed extensive research and modeling of inert gas agent flow to develop a new, novel inert gas suppression nozzle with a low sound power. The Tyco Acoustic Nozzle is a substantial advancement in nozzle technology for the data center market, translating into a solution that can reduce sound exposure to sensitive HDDs and requires significantly less nozzles and piping. With the

need for less piping, the average installation cost may be lower when compared to other acoustic solutions in the market. Figures 8 and 9 are images of the exterior and section view of the nozzle, respectively. This proprietary design is covered by multiple patents on the method of sound reduction and the ability to achieve nozzle distribution performance.

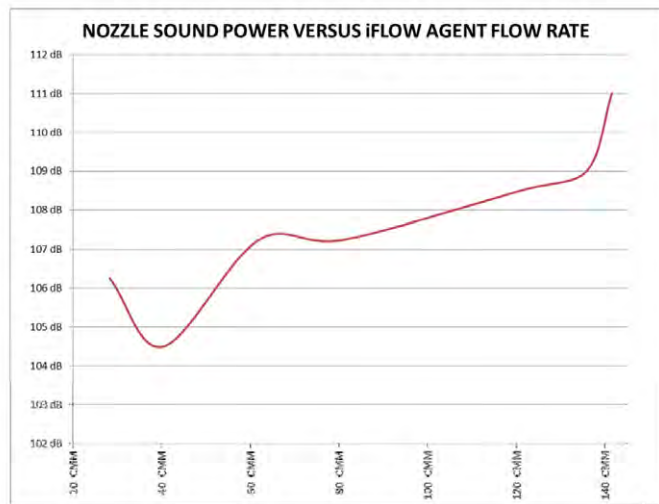
Tyco’s Acoustic Nozzle is a solution for the data center market where the installed HDD could be susceptible to noise. The sound absorbing materials within the nozzle were selected based on the extensive research and physical acoustic testing performed by Tyco. The nozzle has been rigorously tested by Tyco through hundreds of suppression system discharges.

The end result is a nozzle with superior sound power performance and suppression capabilities rivaling standard suppression nozzles. The area coverage and flow capabilities, as tested with Tyco's iFLOW fire suppression system hardware to ANSI UL 2127 nozzle performance tests and in compliance with NFPA 2001, are as follows:

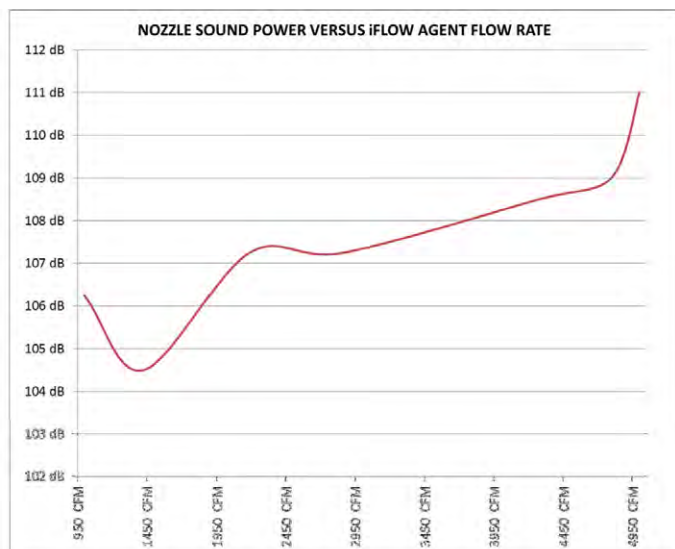
- Maximum protected height per nozzle row: 6.1 m (20 feet)
  - Area coverage: 9.75m x 9.75 m (32' x 32')
  - Agent flow rate capabilities: up to 142 m<sup>3</sup>/min (5000 cfm)
- Tyco characterized the sound power of the new acoustic nozzle across the OTO bands from 500 Hz to 10K Hz. Figure 10, shows the sound power performance of the acoustic nozzle for a system at a specific flow rate. Figures 11 and 12, depict the peak sound power output across the 500 Hz to 10K Hz OTO bands of the nozzle at different agent flow rates.



**Figure 10:** The sound power at one third octave frequency bands for Tyco's Acoustic Nozzle, tested with the iFLOW system with a nozzle agent flow rate of 61.9 m<sup>3</sup>/min (2188 CFM).



**Figure 11:** The peak sound power vs flow rate for Tyco's acoustic nozzle (m<sup>3</sup>/min flow rates)



**Figure 12:** The peak sound power vs flow rate for Tyco's acoustic nozzle (CFM flow rates)

## Tool to Estimate System Sound Performance in a Specific Hazard Area

Every hazard area protected by a fire suppression system will yield varying sound path absorption properties. Data centers should have room acoustic calculations performed to ensure the fire suppression system installation will meet the sound performance requirements to help reduce the risk of HDD degradation should the system discharge. The varying sound path absorption from one data center to another will yield different sound pressure levels at HDDs, so specific room acoustic calculations must be performed. The calculations must provide an estimate of the sound pressure level experienced at a HDD within a protected area. The sound pressure level calculation method requires the use of advanced acoustic formulas to determine the sound absorption between the fire suppression system nozzles and the data center HDDs. The system designer must gather inputs including the hazard area construction materials, location of HDDs, and the sound power level of the suppression nozzles. Once the calculations are performed, the estimated HDD sound pressure level can be compared to the HDD acoustic noise performance curve in Figure 6, the data center noise specification or applicable HDD manufacture data.

Tyco, in conjunction with Michigan Tech, has developed a tool for performing the room acoustic calculations for data centers. Tyco’s Acoustic Calculator was developed to help generate the acoustic calculations to estimate the HDD SPL for a suppression system using the Tyco Acoustic Nozzle.

The Acoustic Calculator simplifies the calculation by containing drop down selection menus for the suppression system parameters as well as selection of room materials. This enables Tyco’s Technical Services team to perform calculations tailored to each customer installation. Figure 13 shows screen shots and an example output plot from the tool.

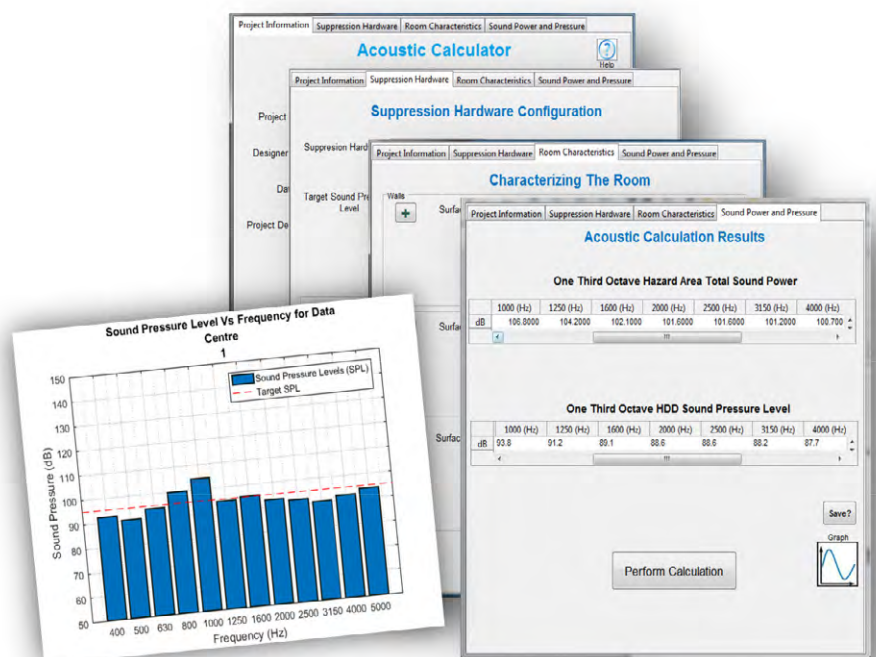


Figure 13: Screen shots and output plot from Tyco’s Acoustic Calculator

## Additional Recommended Noise-Control Measures

In conclusion, Tyco's comprehensive HDD research has identified the noise sensitivity of enterprise HDDs, using the largest population of HDDs tested to date. Tyco recommends that data centers specify sound pressure levels of 110 dBZ or below across 500Hz – 10KHz frequency bands at HDD locations. Data center owners and operators must also consider the sound-path-receiver paradigm and understand that sound is generated as sound power at a source and transformed through the room paths to generate the sound pressure at HDDs. Tyco's Acoustic Calculator allows system designers to design the placement of suppression nozzles and to account for room acoustic properties to estimate the HDD sound pressure level. Tyco's continued commitment to creating solutions for the data center market has led to the development a new low sound power fire suppression nozzle. As needs arise for fire suppression system design and installation in data, Tyco encourages you to contact us for additional information or technical support.

## About the Authors

**Derek Sandahl** has spent 12 years working in the fire protection industry for Tyco Fire Protection Products. He is the applicant on several patents, including two for fire suppression nozzle technologies. He is holder of BS degree from Lake Superior State University and MS degree from University of Wisconsin Green Bay.

**Alan Elder** is Industry Fellow - Engineered Systems for Tyco Fire Protection Products. He is the UK Principal Expert to ISO, Chairman of various technical committees, including British Standards FSH18/6, Fire Industry Association - Working Group Gases, EUROFEU Fixed Extinguishing Installations Section and a member of several CEN TC191 technical committees.

**Dr. Andrew Barnard** is an Assistant Professor of Mechanical Engineering- Engineering Mechanics at Michigan Technological University since 2014. Prior to joining Michigan Tech, he was a Research Associate at the Applied Research Laboratory at Penn State for 8 years. Dr. Barnard holds B.S. and M.S. degrees in Mechanical Engineering from Michigan Technological University and a Ph.D. in Acoustics from The Pennsylvania State University. Dr. Barnard's specialties include structural acoustics, architectural acoustics, acoustic measurements, signal

processing, and sound intensity. He is a Board Certified member of the Institute for Noise Control Engineering (INCE-USA) currently serving as a Director on the Board of Directors. He is also a Certified LabVIEW Developer (CLD). Dr. Barnard has published 14 peer-reviewed journal articles and 41 non-refereed articles and conference proceedings.

Tyco Fire Protection Products is a world leader in the development, approval and manufacture of all types of gaseous, water mist, water sprinkler and foam systems, and can therefore offer solutions based on the most appropriate technology for the protected hazard.

## References

- Acoustical Society of America. (2012, February 23). Acoustics - Determination of sound power levels and sound energy levels of noise sources using sound pressure - Precision methods for reverberation test rooms. American National Standard. Melville, NY: ANSI.
- Barnard, A. R. (2014, July ). Quantifying Acoustic Sources Through Sound Power Measurements. *Sound & Vibration*, 48(7), p. 8.
- Lixin, J., & Macioce, P. (2007). Fundamentals of Hard Disk Drive Acoustics.
- Nelson, D., Pai, N., & Nickerson, M. (2011). Hard Disk Performance Degradation Due to High Level Noise in Data Centers. 40th International Congress and Exposition on Noise Control Engineering (p. 107). Inter-Noise 2011: Curran Associates.
- Nickerson, M. L., Green, K., & Pai, N. (2013). Tonal noise sensitivity in hard drives. *Journal of the Acoustic Society of America* 134.5, 4222.
- Rawson, B. P., & Green, K. C. (2007). Inert Gas Data Center Fire Protection and Hard Disk Drive Damage. *Datacenter Journal*, <http://www.datacenterjournal.com/inert-gas-data-center-fire-protection-and-hard-disk-drive-damage/>.
- Underwriters Laboratories. (2016, June 24). Standard for Safety for Inert Gas Clean Agent Extinguishing Units, UL2127. ANSI / UL 2127, Second Edition. Northbrook, IL: Underwriters' Laboratories.







**Global Strength. Local Expertise.**  
**At your Service.**

---

---